

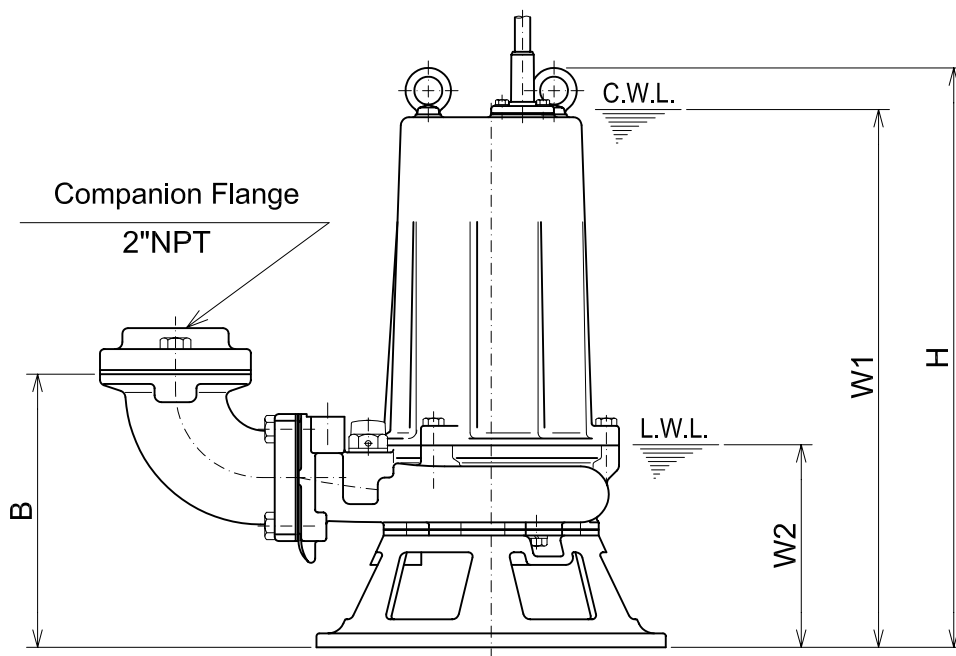

**B-SERIES**  
SEWAGE & WASTEWATER PUMPS

**DIMENSIONS**

50B2.75H -63

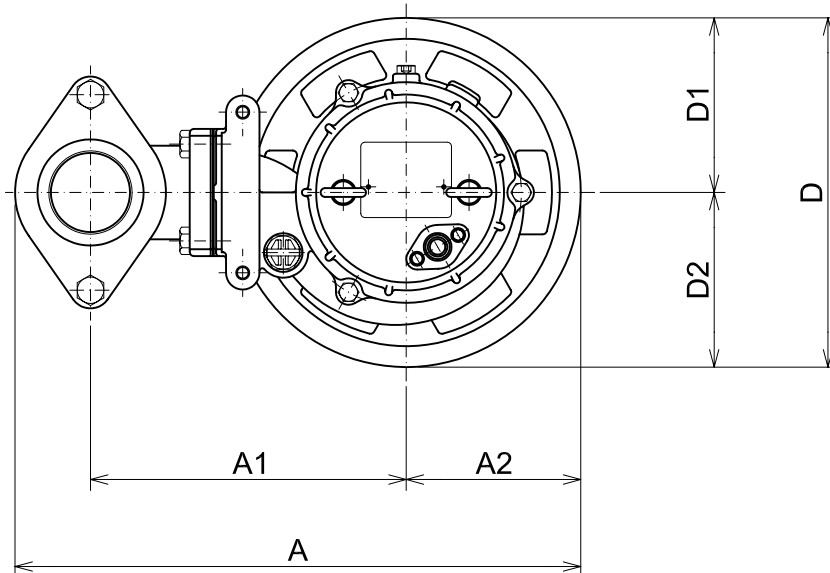

C.W.L. :Continuous running Water Level  
L.W.L. :Lowest running Water Level

**DIMENSIONS:USCS(Inch)**

Model	HP	NOM. SIZE	Pump & Motor								C.W.L.	L.W.L.	Wt. (lbs.)
			A	A1	A2	B	D	D1	D2	H			
50B2.75H -63	1	2"	15 15/16	8 7/8	4 15/16	7 11/16	9 13/16	4 15/16	4 15/16	16 5/16	15 1/8	5 3/4	53

**DIMENSIONS:METRIC(mm)**

Model	kW	NOM. SIZE	Pump & Motor								C.W.L.	L.W.L.	Wt. (kg)
			A	A1	A2	B	D	D1	D2	H			
50B2.75H -63	0.75	50	405	226	125	196	250	125	125	415	385	145	24

**TOS50B2.75H -63**

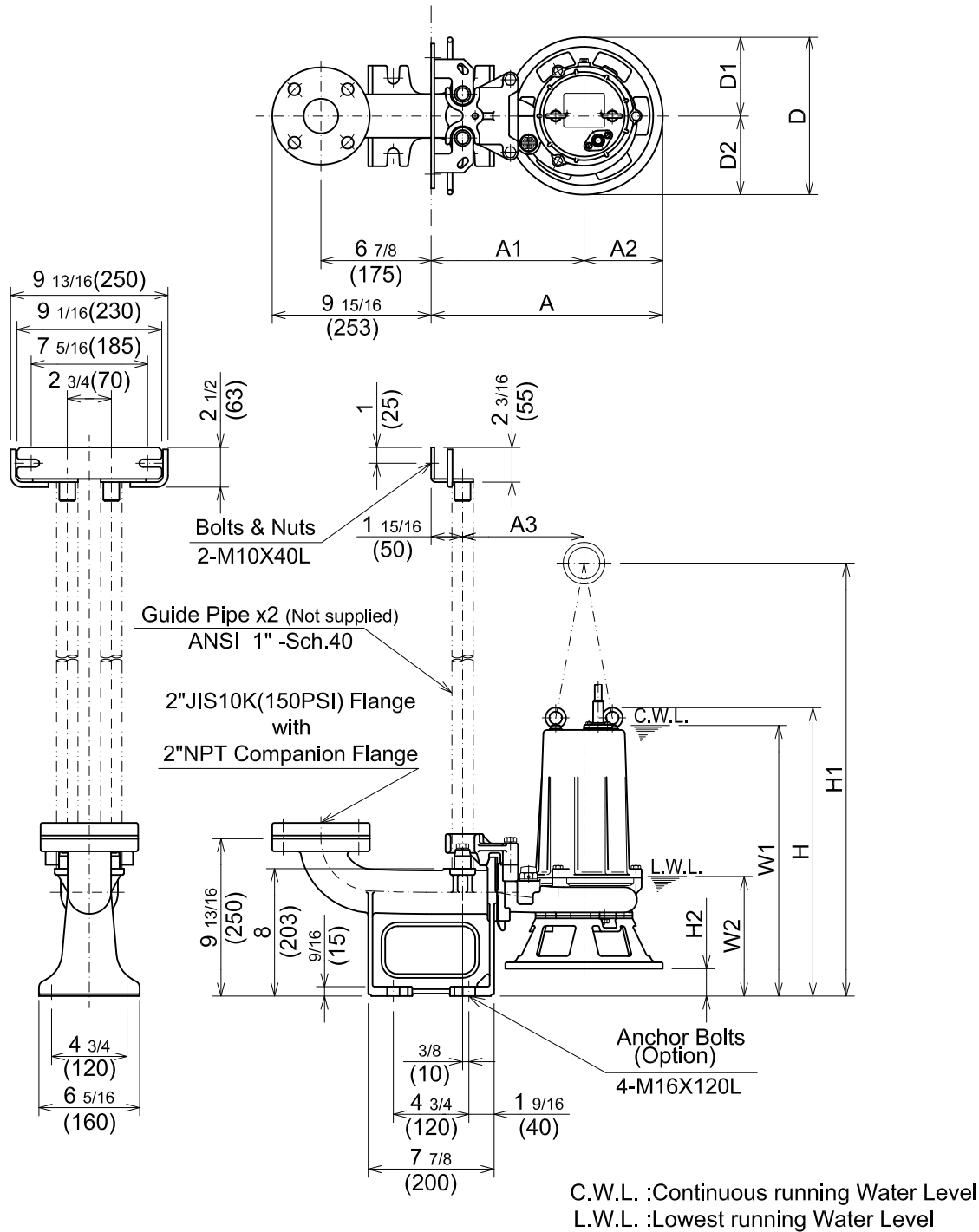

**DIMENSIONS:USCS(Inch)**

Model	HP	NOM. SIZE	Pump & Motor									C.W.L.	L.W.L.	Wt. (lbs.)	
			A	A1	A2	A3	D	D1	D2	H	H1				H2
TOS50B2.75H -63	1	2"	14 1/2	9 9/16	4 15/16	7 5/8	9 13/16	4 15/16	4 15/16	18 1/16	27 1/8	1 3/4	16 7/8	7 1/2	51

**DIMENSIONS:METRIC(mm)**

Model	kW	NOM. SIZE	Pump & Motor									C.W.L.	L.W.L.	Wt. (kg)	
			A	A1	A2	A3	D	D1	D2	H	H1				H2
TOS50B2.75H -63	0.75	50	368	243	125	193	250	125	125	458	688	44	430	190	23



# B - SERIES

SEWAGE & WASTEWATER PUMPS

PERFORMANCE  
CURVE

MODEL		BORE	HP	KW	RPM	SOLIDS DIA.	LIQUID	SG.	VISCOSITY	TEMP.
(TOS)50B2.75H -63		2"/50mm	1	0.75	3380	0.787"/20mm	Water	1.0	1.123cSt.	60°F
PUMP TYPE		PHASE	VOLTAGE		AMPERAGE		HZ	STARTING METHOD		INS. CLASS
Sewage & Wastewater		3	208-230/460/575		3.5-3.5 / 1.8 / 1.4		60	Direct On Line		E
CURVE No.	DATE	PHASE	VOLTAGE		AMPERAGE		HZ	STARTING METHOD		INS. CLASS
-	-	-	-		-		-	-		-

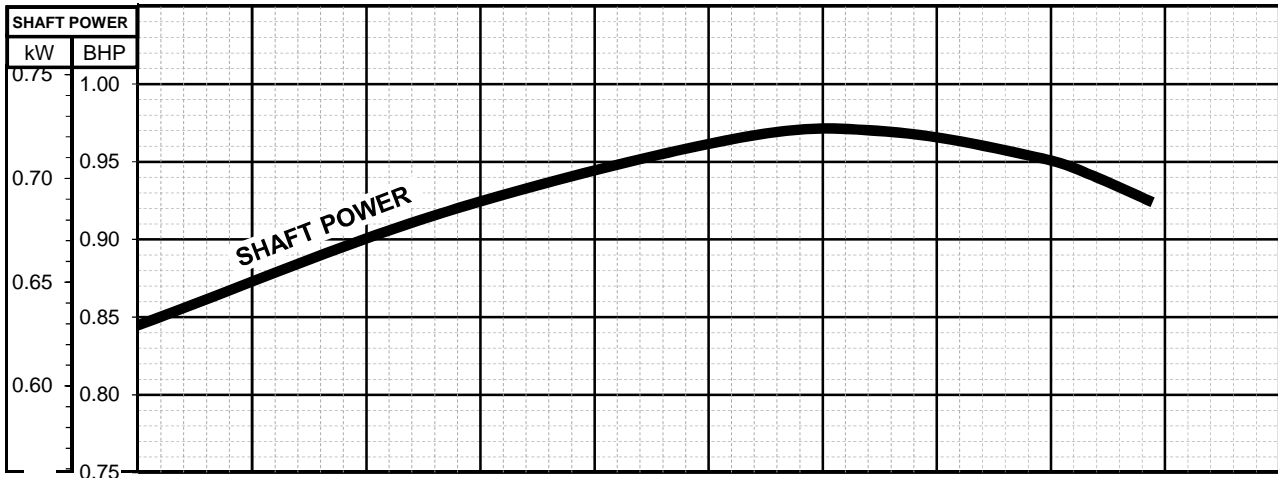
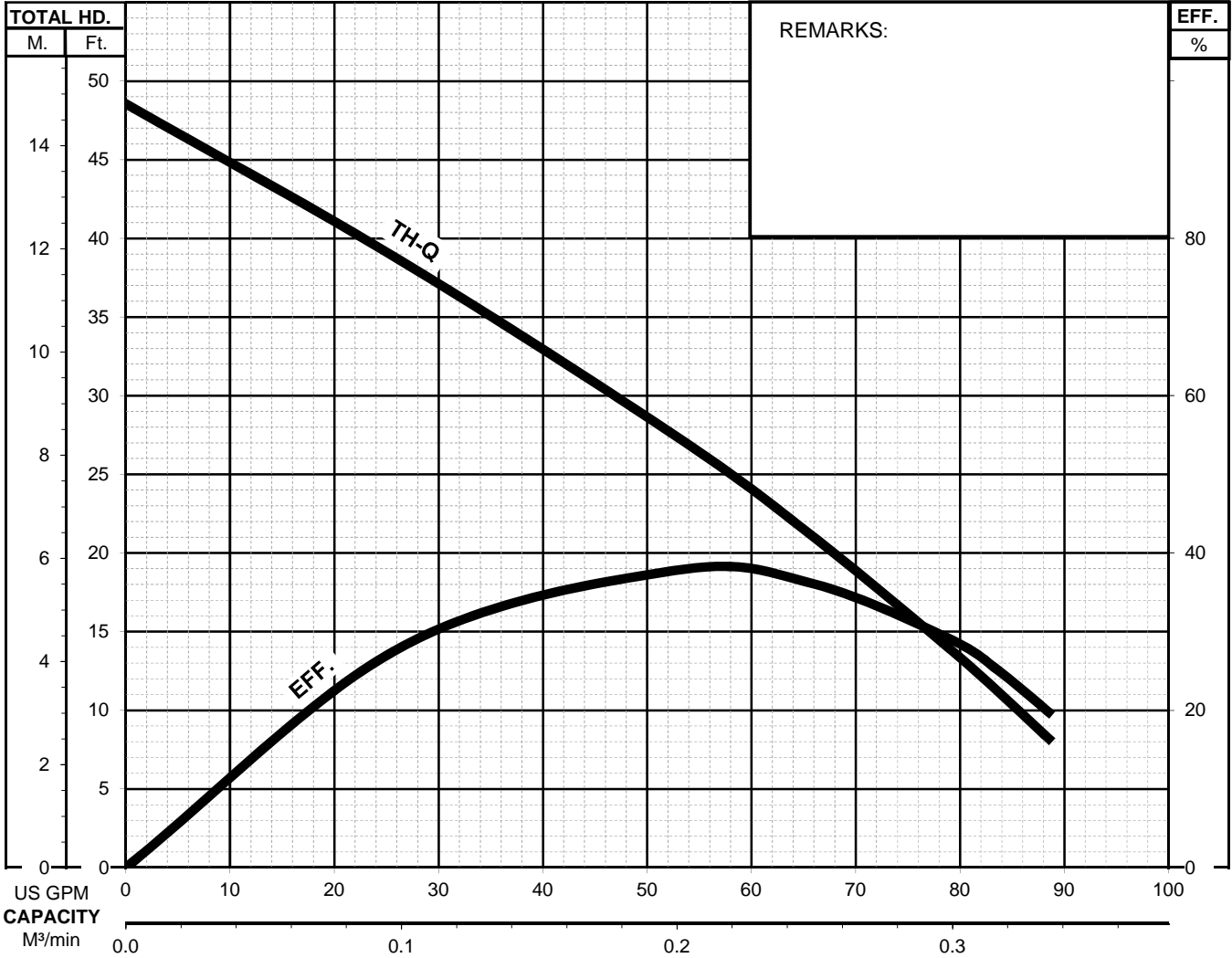

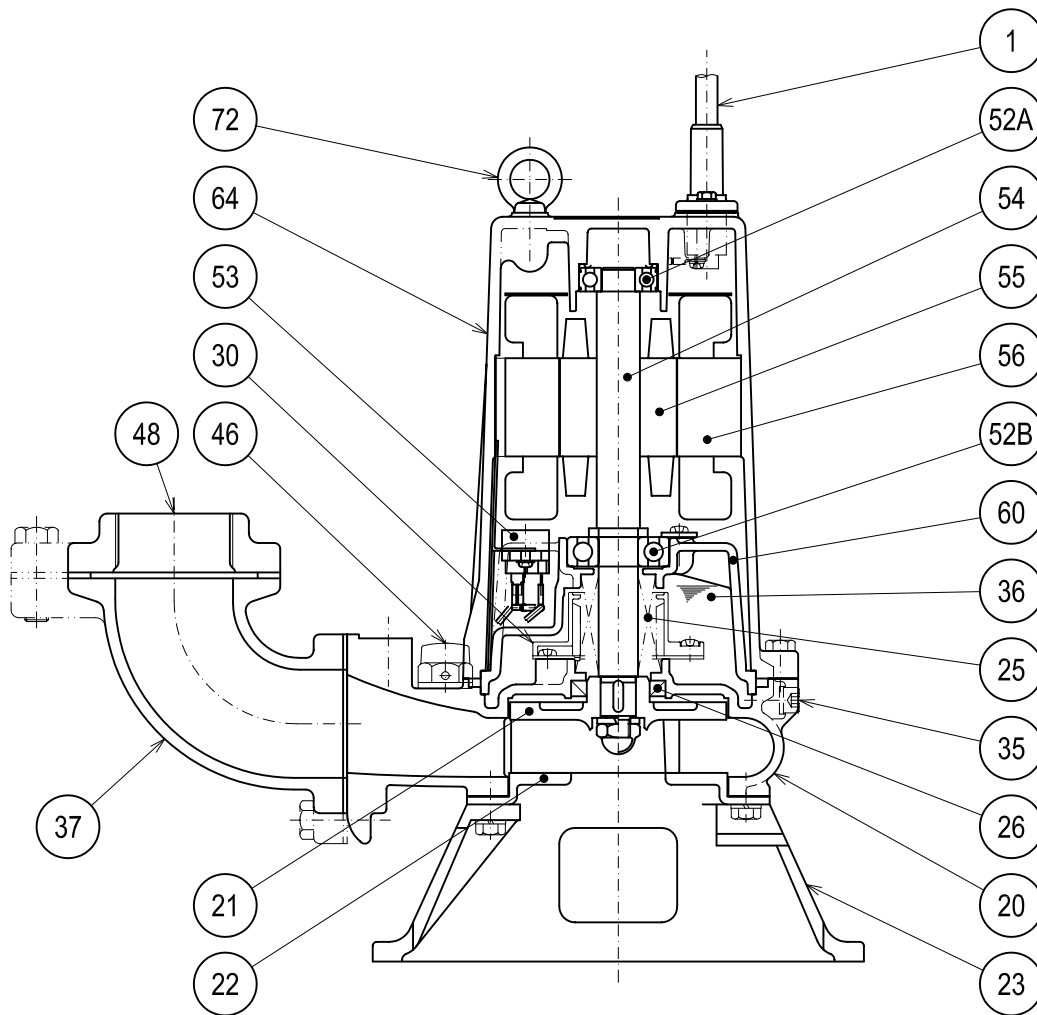
**TSURUMI PUMP**
**B-SERIES**  
**SEWAGE & WASTEWATER PUMPS**
**SECTIONAL VIEW****50B2.75H -63**

PART#	DESCRIPTION	MAIN MATERIAL / NOTE	RELATED ASTM,AISI CODE	RELATED EN CODE	QTY
1	Power Cable	PVC Sheath AWG 16/4-32ft			1
20	Pump Casing	Cast Iron	A48M Class30B	EN 1561 GJL-200	1
21	Impeller	Cast Iron	A48M Class30B	EN 1561 GJL-200	1
22	Suction Cover	Cast Iron	A48M Class30B	EN 1561 GJL-200	1
23	Suction Strainer	Ductile Cast Iron	A536 65-45-12	EN 1563 GJS-450-10	1
25	Mechanical Seal	Silicon Carbide / H-20			1
26	Oil Seal	NBR / TC32488			1
30	Oil Lifter	PBT Resin W/GF40			1
35	Oil Plug	Stainless Steel	S 30400	1.4301	1
36	Lubricant	Turbine Oil ISO VG32 or SAE 10W-20			
37	Discharge Bend	Cast Iron	A48M Class30B	EN 1561 GJL-200	1
46	Air Release Valve	Nylon			1
48	Companion Flange	Cast Iron / NPT 2"	A48M Class30B	EN 1561 GJL-200	1
52A	Upper Bearing	AC-#6203ZZC3			1
52B	Lower Bearing	#6304ZZC3			1
53	Motor Protector				1
54	Shaft	Stainless Steel	S 40300	1.4000	1
55	Rotor				1
56	Stator				1
60	Bearing Housing	Cast Iron	A48M Class25B	EN 1561 GJL-150	1
64	Motor Housing	Cast Iron	A48M Class25B	EN 1561 GJL-150	1
72	Lifting Lug Bolt	Stainless Steel	S 30400	1.4301	2

PARTS LIST		SEWAGE & WASTEWATER PUMPS			4/9/2018	
ITEM	PART No.	DESCRIPTION	QTY	SIZE	MATERIAL	NOTES
1	001-803-20	Cabtyre Cable Set (32') 60Hz(USA)	1	VCT4Cx1.25mm2	LBT	
2	140-427-17	Hex.Bolt (w/Plain Washer)	2	M5x15	SUS304	
3	003-190-10	Gland	1		SUS316	
4	072-105-25	Eye Bolt	2	M8	SUS304	
5	064-000-64	Motor Frame	1		FC	
6	140-056-11	Hex.Bolt	3	M8x30	SUS304	
7	142-194-18	Wave Washer	1	6203	SK5	
8	052-186-15	Bearing (w/O-ring)	1	AC-6203ZZC3		
9	058-000-34	Lead Wire Protection Plate	1	d52xd115x1.2t	GFRP	interchangeable with OLD part# 058-115-11 (bakelite)
10	009-112-16	Earth Terminal	1Set	1.25mm2		
11	143-085-34	Pan Screw (w/Spring Washer)	1	M4x6	C3604	
12	056-003-27	Stator 220V-60Hz(USA)	1Set			
	056-003-31	Stator 440V-60Hz(USA)	1Set			
	056-003-33	Stator 575V-60Hz(USA)	1Set			
13	127-000-32	Protector Fixing Plate	1	P.C.39.5x117L	SECC	
14	053-001-29	Motor Protector 220V-60Hz(USA)	1	KA311-DBXL55	(T.C)	
	053-465-14	Motor Protector 440V-60Hz(USA)	1	KA311-DPXL62C	(T.C)	
	053-444-17	Motor Protector 575V-60Hz(USA)	1	KA311-DPXL65	(T.C)	
15	143-126-12	Pan Screw (w/Spring Washer/Plain Washer)	2	M4x12	SWRM	
16	055-001-19	Rotor (1st)	1Set	w/Bearing		
	055-002-29	Rotor (2nd)	1Set	w/Bearing		
17	147-038-18	Impeller Key	1	5x5x15.5L	SUS420	
18	061-000-03	Bearing Collar (1st)	1	d20xd30x4.5t	FC	
19	140-000-23	Hex.Bolt (w/Spring Washer)	2	M5x10	SWRM	
20	062-187-17	Bearing Fixing Washer	2	d5.5xd18x2.3t	SPC	
21	052-107-12	Bearing	1	6304ZZC3		
22	060-000-64	Bearing Housing	1		FC	
23	025-192-10	Mechanical Seal	1	H-20	SiC	
24	143-070-23	Pan Screw	2	M5x6	SWRM	
25	030-144-13	Oil Lifter	1	H-20(A)(T)	Resin	
26	143-070-10	Pan Screw	2	M5x6	SWRM	
27	030-153-15	Seal Stopper	1	H-20(A)	SPCC	
28	122-072-17	O-Ring	1	P-140(139.6xd5.7)	NBR	*
29	046-107-13	Air Release Valve	1	PT-1/2	Nylon	
30	035-112-17	Oil Plug	1	M8x12	SUS304	
31	121-248-13	Packing	1	d8.2xd13.5x2t	PE	*
32	020-610-14	Pump Casing	1	8-BEH2	FC	
33	026-107-11	Oil Seal	1	TC-32488	NBR	

PARTS LIST		SEWAGE & WASTEWATER PUMPS			4/9/2018	
ITEM	PART No.	DESCRIPTION	QTY	SIZE	MATERIAL	NOTES
34	040-104-25	Impeller Shim		d18.2xd29x0.3t	SUS304	
35	021-731-15	Impeller (60Hz)	1	50B2.75H-63	FC	
	021-730-14	Impeller (50Hz) OPTION	1	50B2.75H-53	FC	50Hz OPTION
36	142-165-10	Spring Washer	1	M12	SUS304	
37	141-118-15	Hex.Cap Nut	1	M12(H=15.5)	SUS304	
38	120-145-16	Packing (S.Cover)		d112xd129x0.3t	PE	
39	022-569-13	Suction Cover	1	8-BE2	FC	
40	140-475-10	Hex.Bolt (w/Spring Washer)	3	M8x16	SUS304	
41	023-001-25	Strainer Stand	1	No.1(8-BE2/CE2)	FC	
42	140-476-11	Hex.Bolt (w/Spring Washer)	3	M8x25	SUS304	
43	048-136-17	Screwed Flange	1	NPT-2(P.C.140)	FC	
43	048-181-17	Screwed Flange	1	NPT-2+1/2(P.C.140)	FC	
44	140-099-16	Hex.Bolt	2	M12x40	SUS304	
45	121-137-18	Packing	1	MBT(P.C.140)	NBR	*
46	037-117-18	Discharge Bend	1	50mm(122-16)	FC	
47	140-078-19	Hex.Bolt	4	M10x35	SUS304	
48	121-142-16	Packing	1	90mm2(P.C.98)	NBR	*
	173-336-10	<b>Packing O-Ring Set</b>	1Set	(Marked by *)		
28	122-072-17	O-Ring (M.Frame/P.Casing)	1	P-140(139.6xd5.7)	NBR	*
31	121-248-13	Packing (Oil Plug)	1	d8.2xd13.5x2t	PE	*
45	121-137-18	Packing (Screwed Flange)	1	MBT(P.C.140)	NBR	*
48	121-142-16	Packing (Discharge Bend)	1	90mm2(P.C.98)	NBR	*
		Lubricant		Turbine Oil VG32 420ml		

PARTS LIST		SEWAGE & WASTEWATER PUMPS				4/9/2018
ITEM	PART No.	DESCRIPTION	QTY	SIZE	MATERIAL	NOTES

## EXPLODED VIEW

50B2.75-53/63  
50B2.75H-53/63

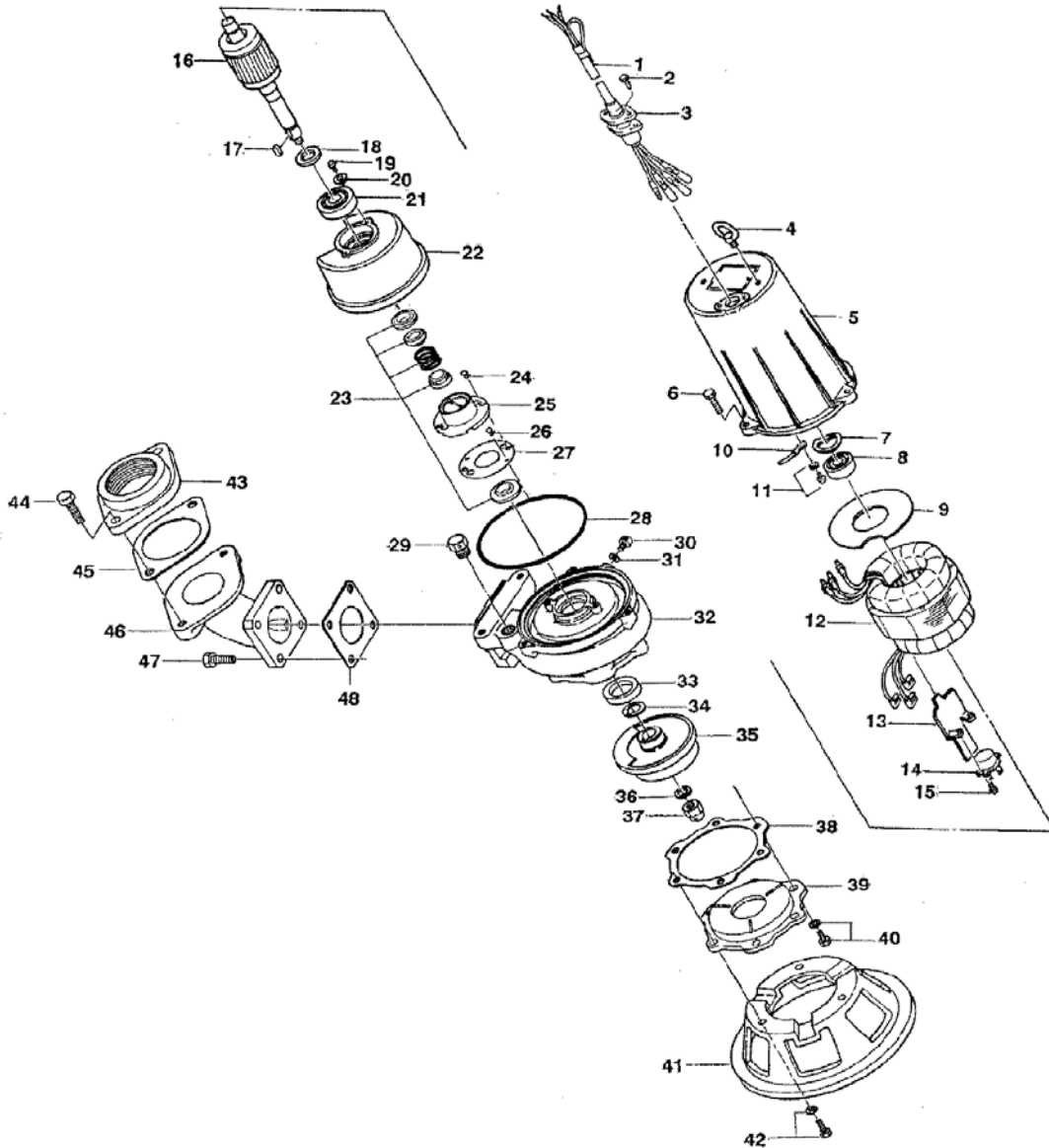

C-00641-1